

## Type 6011BB

### PRIASAFE™ Miniature cavity pressure sensor

- Mounting proof sensor with housing
- No deviation of calibrated value after mounting
- Very small dimensions
- Sensor front can be machined to adapt the cavity surface
- Can be connected to any charge amplifier respectively injection molding machine
- Patent pending

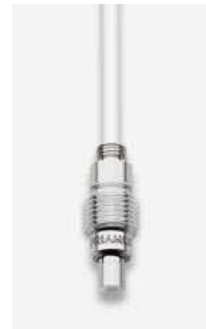

### Description

A cavity pressure sensor is a highly sensitive measuring instrument that can – if not mounted properly – give wrong measuring results. A possible cause is the so called force shunt which generates a sensitivity loss of the sensor when the sensor front touches the bore.

To prevent this, the cavity pressure sensor type 6011BB is mounted into a housing and then calibrated. This procedure has the advantage that the sensitivity does not change after the sensor has been installed into the mold because it is “protected” by the housing. In a second step the determined sensitivity will be saved inside the sensor by a hardware code. With the help of this hardware code the sensor sensitivity can then be automatically detected without being influenced by the sensor installation. The sensor is therefore easy to use, safe and most suitable for industrial production.

### Technical data

Measuring range	bar	0 ... 2000
Overload	bar	2500
Sensitivity <sup>1)</sup>	pC/bar	- 2
Maximum melt temperature (plastics) in the cavity <sup>2)</sup>	°C	no limitation
Maximum mold temperature <sup>3)</sup>	°C	200
Deviation of linearity	%	< ± 1
Natural frequency <sup>4)</sup>	kHz	> 80
Insulation resistance	Ω	> 10 <sup>13</sup> (at 20 °C)

#### Remark

The sensors including connecting cable can be cleaned in an ultrasonic bath together with the mold inserts if a sealed protecting cap is used (cleaning agent: aqueous tenside solution).

- <sup>1)</sup> The exact sensitivity is shown on a separate calibration sheet
- <sup>2)</sup> The plastic melt cools immediately after contacting the cavity wall. The melt temperature is therefore without any practical meaning for the sensor (thermoplastics). For thermosets and elastomers the permanent melt temperatures are usually below 200 °C
- <sup>3)</sup> The permanent temperature of the sensor body can be higher than the specified value of the mold temperature. The temperature at the cable connector however is limited. In practice there are no mold temperatures higher than 200 °C expected.
- <sup>4)</sup> The actual natural frequency of the sensor is far higher than the frequency spectrum of the effective signal

## Dimensions

### Type 6011BB...

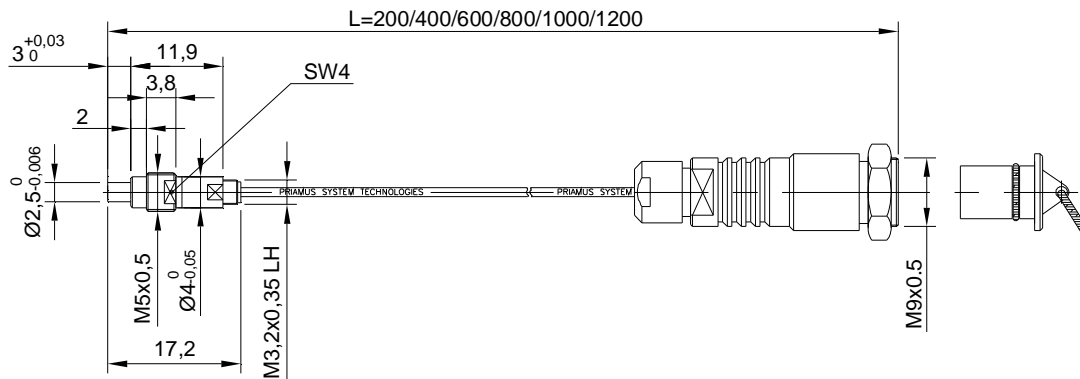

## Mounting dimensions

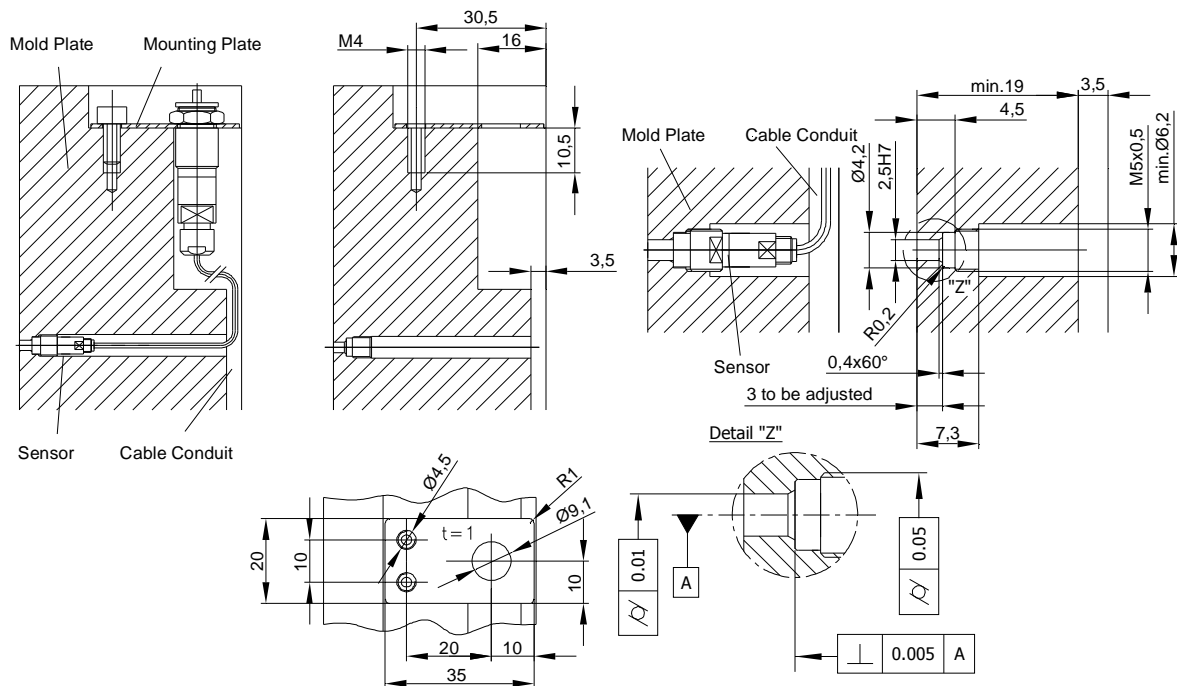

subject to technical amendments



### Scope of delivery

Article	Type	Article	Type
Mounting plate	6581B	Identification label	-

### Accessories

Article	Type	Article	Type
Mounting / extraction tool with left-hand thread for sensors	6569A	Connecting cable	1051A... / 1065A...
Mounting tool to tighten the sensor	6570A	Extension cable	1061A...
Dummy	6515A		

### Order codes

Sensor: Type 6011BB  
Sensor incl. connecting cable type 1008A...: Type 6011BB0,2 / 0,4 / 0,6 / 0,8 / 1,0 / 1,2 / 2,0 / 3,0 / 4,0 / 5,0

subject to technical amendments