

Type 8903

PDDI

PRIAMUS Digital Data Interface

- Standardized interfaces
- Overload protection
- Alarm signals
- Switching signals (holding pressure, sequential)
- Measuring data (analog)
- Device supply
- Supply of the digital output signals

8903D1

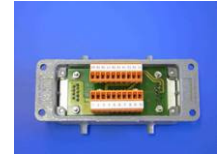

8903E2



8903B3

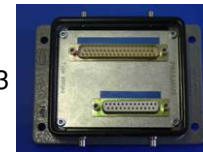

Description

Analog measuring data as well as digital signals e.g. for part containment (alarm), for the control of shut-off valves (sequential molding) or for switchover to holding pressure must be connected to the machine control by an interface.

Due to the lack of a standardized interface on the part of the machine builders PRIAMUS provides these interfaces for installation in the control cabinet.

After installation and interfacing of the signals to the respective clamps the single signal groups can be connected to the electronics (usually eDAQ™ type 8102B...) by simply plugging the color coded connecting cables.

The digital data communication with the electronics (eDAQ™) is galvanically isolated via optocouplers. The output drivers of the eDAQ™ are equipped with an overload fuse and a pole fuse. In addition, any outputs on the same connector can be connected.

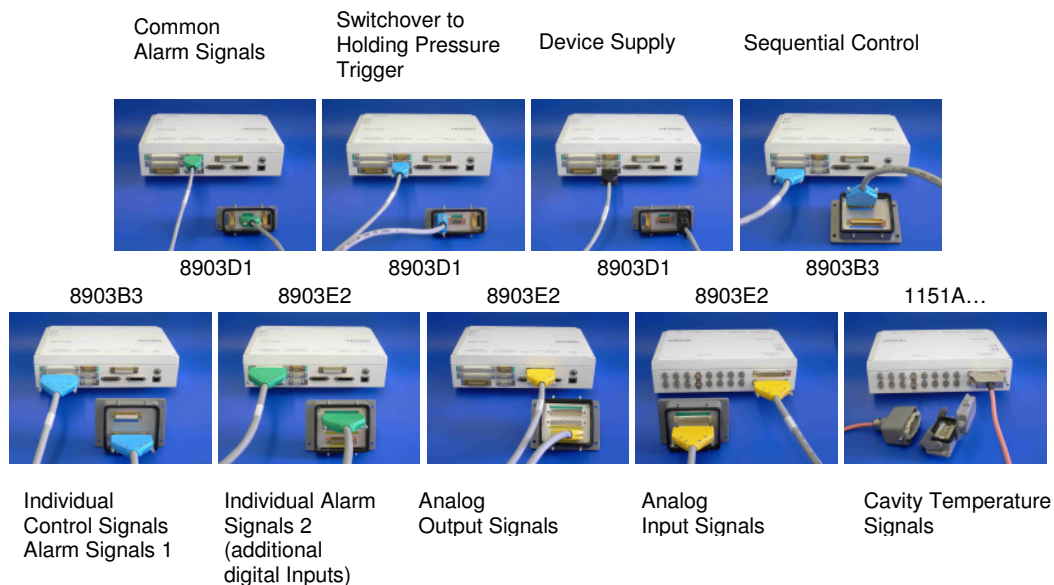

Subject to technical amendments

PDDI type 8903D1

The PDDI Type 8903D1 is used for interfacing following signals:

| <i>Signal</i> | <i>Description</i> | <i>Interface</i> |
|---|---|--|
| Proximity trigger Trigger Supply in V+ | Proximity switch or non-isolated trigger Machine trigger (e.g. start injection) Device supply from PRIAMUS power supply type 9005A | +24 V to eDAQ™ +24 V to eDAQ™ +24 V to eDAQ™ |
| Supply in GND Common alarm Auto switchover alarm 1 Auto switchover alarm 2 Alive Auto switchover Switchover Dig_Out 0 Trigger GND | Device supply GND power supply type 9005A Common alarm of different functions Common alarm 1 / automatic switchover (SLP) Common alarm 2 / automatic switchover (SLP) Functional check of the eDAQ™ Automatic switchover to holding pressure (SLP) Switchover to holding pressure (SL) / level Monitoring On / Off GND to machine trigger | GND to eDAQ™ +24 V to machine +24 V to machine +24 V to machine +24 V to machine +24 V to machine +24 V to machine GND to eDAQ™ |
| <i>Signal</i> | <i>Description</i> | <i>Interface</i> |
| Iso supply out eDAQ V+ Iso GND out eDAQ Iso supply in (eDAQ or machine) V+ Iso GND in (eDAQ or machine) | Supply of the output stages by the eDAQ™ Supply GND of the output stages (eDAQ™) Supply of the output stages by the machine Supply GND of the output stages (machine) | +24 V from eDAQ™ GND from eDAQ™ +24 V from machine GND from machine |

Dimensions PDDI type 8903D1

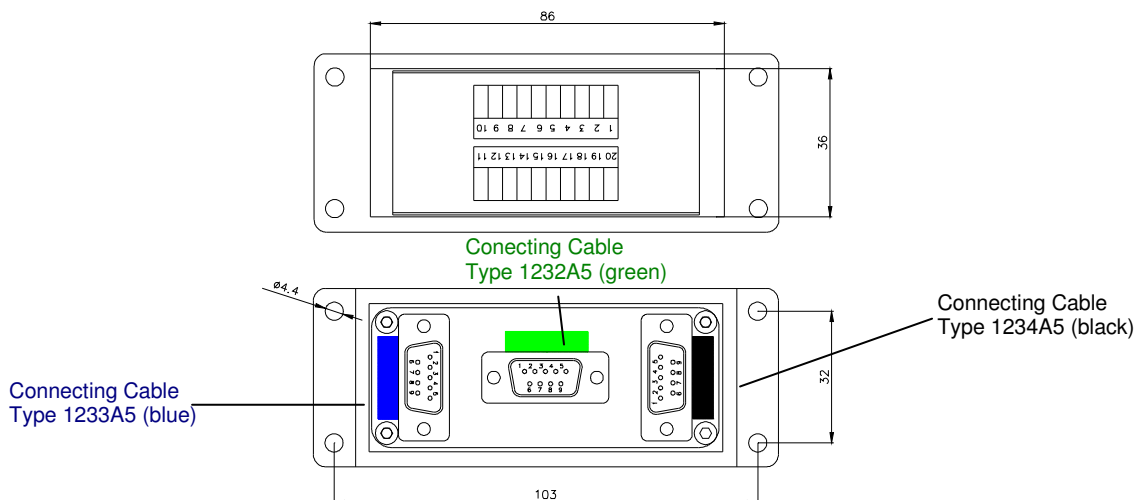

Subject to technical amendments

Pin allocations PDDI type 8903D1

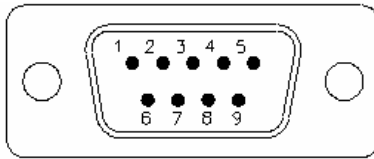

Connecting Cable
Type 1234A5 (black)

| Pin | Function |
|-----|---|
| 1 | Proximity trigger (non-isolated trigger / proximity switch) |
| 2 | Supply in V+ (device supply) |
| 3 | Supply in GND (device supply) |
| 4 | Supply in GND (device supply) |
| 5 | Supply in V+ (device supply) |
| 6 | Supply in V+ (device supply) |
| 7 | Supply in GND (device supply) |
| 8 | Supply in V+ (device supply) |
| 9 | Supply in GND (device supply) |

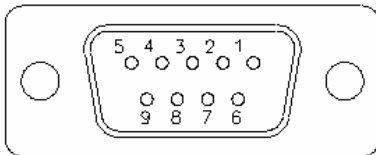

Connecting Cable
Type 1232A5 (green)

| Pin | Function |
|-----|------------------------------------|
| 1 | Common alarm |
| 2 | Auto switchover alarm1 |
| 3 | Switchover alarm |
| 4 | Alive |
| 5 | Auto switchover alarm2 |
| 6 | Iso GND out eDAQ |
| 7 | Iso supply out eDAQ V+ |
| 8 | Iso supply in (eDAQ or machine) V+ |
| 9 | Iso GND in (eDAQ or machine) |

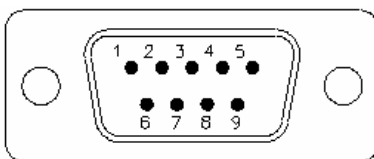

Connecting Cable
Type 1233A5 (blue)

| Pin | Function |
|-----|---|
| 1 | Trigger Signal + |
| 2 | Trigger GND (-) |
| 3 | Iso GND In (eDAQ or Machine) |
| 4 | Auto Switchover, (ComSLP, Collective SLP) |
| 5 | Iso Supply In (eDAQ or Machine) V+ |
| 6 | Iso Supply Out eDAQ V+ |
| 7 | Dig_Out0 (Monitoring On / Off) |
| 8 | Switchover, (ComSL, Collective SL) |
| 9 | Iso GND Out eDAQ |

Subject to technical amendments



Clamp interface machine side PDDI type 8903D1

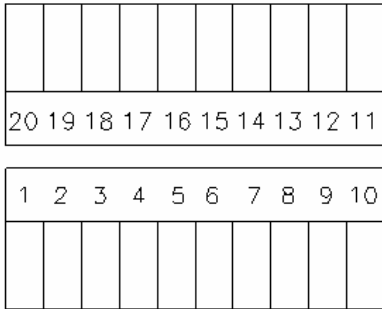

| Clamp # | Signal | Interface |
|---------|---|--------------------------------------|
| 1 | Dig In Trigger Proxi DSUB9 black | +24V to eDAQ |
| 2 | Supply in V+ (Device Supply) | +24V to eDAQ Priamus |
| 3 | Supply in GND (Device Supply) | GND Priamus |
| 4 | Dig Out Common Alarm DSUB9 green | +24V to Machine |
| 5 | Dig Out Auto Switchover Alarm 1 | +24V to Machine Select SLP Alarm1 |
| 6 | Dig Out Switchover Alarm | +24V to Machine Select SL Alarm |
| 7 | Dig Out Alive | +24V to Machine |
| 8 | Dig Out Auto Switchover Alarm 2 | +24V to Machine Select SLP Alarm2 |
| 9 | Iso Supply Out (eDAQ, V+) | +24V from eDAQ |
| 10 | Iso Supply In (eDAQ or Machine, V+) | +24 V Machine Common Alarm |
| 11 | Iso GND In (eDAQ or Machine) | GND Machine Common Alarm |
| 12 | Dig In Trigger GND (-) Machine DSUB9 blue | GND from Machine |
| 13 | Dig In Trigger Signal (+) Machine | +24V to eDAQ |
| 14 | Dig Out Auto Switchover | +24V to Machine Select SLP |
| 15 | Dig Out DIG OUT0 (Monitoring On / Off) | +24V to Machine |
| 16 | Dig Out Switchover | +24V to Machine Select SL |
| 17 | Iso Supply Out (eDAQ, V+) | +24V from eDAQ |
| 18 | Iso Supply In (eDAQ or Machine, V+) | +24 V Machine Switchover |
| 19 | Iso GND Out (eDAQ) | GND from eDAQ |
| 20 | Iso GND In (eDAQ or Machine) | GND Machine Switchover |

Subject to technical amendments

PDDI type 8903E2

The PDDI Type 8903E2 is used for interfacing following signals:

| <i>Signal</i> | <i>Description</i> | <i>Interface</i> |
|---|--|--|
| Alarm 2 Dig out1 Dig out2 Dig in option Common logic in - In Ch1...16 (Supply GND) + In Ch1...16 Out Ch1...16 Signal GND Dig out 3...7 | Additional alarm signals for channels 1...16 Machine STOP Balance/Control On / Off digital input signals Reference point for DigIn option GND of input signals Analog input signals (e.g. machine signals) Analog output signals GND of the output signals Digital outputs, e.g. for PRIAMUS Fill | +24 V to machine +24 V to machine +24 V to machine +24 V to eDAQ GND from machine GND from machine ± 10 V ± 10 V to machine GND to machine +24 V to machine |
| Iso supply in (eDAQ or machine) V+ Iso GND in (eDAQ or machine) | Supply of the output stages by the machine Supply GND of the output stages (machine) | +24 V from machine GND from machine |

Dimension PDDI type 8903E2

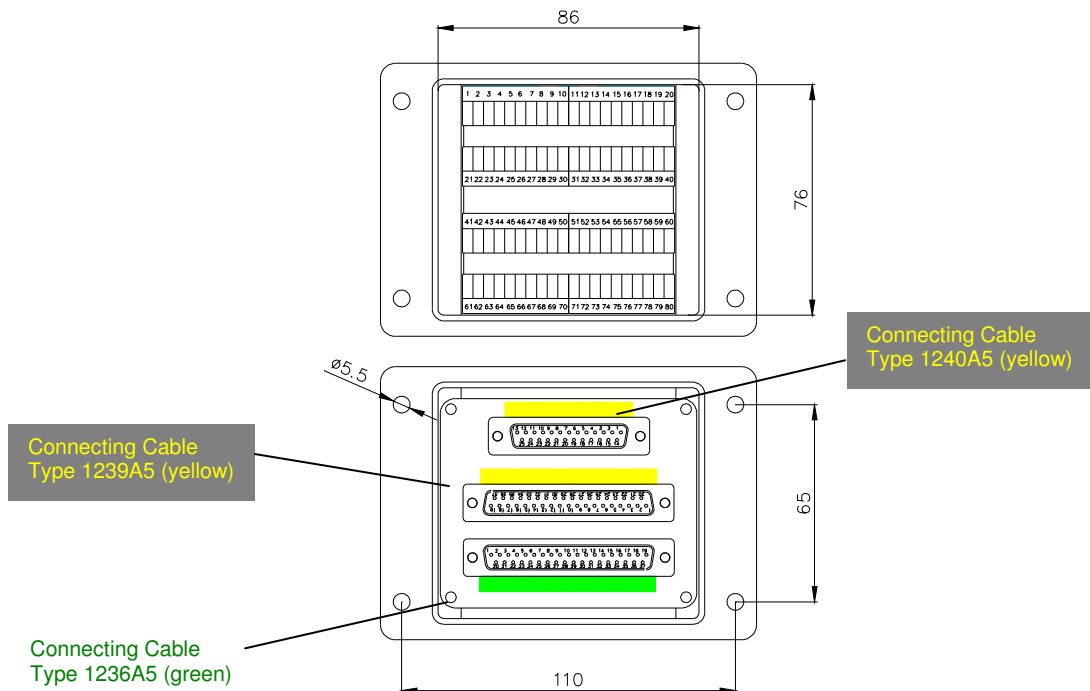

Subject to technical amendments

Pin allocation PDDI type 8903E2

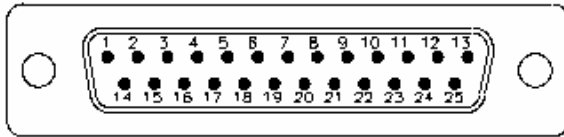

Connecting Cable
Type 1240A5 (yellow)

| Pin | Function | Pin | Function |
|-----|--|-----|------------------------------------|
| 1 | Out Ch 1 | 14 | Signal GND |
| 2 | Out Ch 2 | 15 | Out Ch 9 |
| 3 | Out Ch 3 | 16 | Out Ch 10 |
| 4 | Out Ch 4 | 17 | Out Ch 11 |
| 5 | Out Ch 5 | 18 | Out Ch 12 |
| 6 | Out Ch 6 | 19 | Out Ch 13 |
| 7 | Out Ch 7 | 20 | Out Ch 14 |
| 8 | Out Ch 8 | 21 | Out Ch 15 |
| 9 | Supply GND | 22 | Out Ch 16 |
| 10 | Dig Out 3 (Warning Hot runner) | 23 | Dig Out 7 (Bad part) |
| 11 | Dig Out 4 (Warning max. Balancing time) | 24 | Iso Supply In (eDAQ or Machine) V+ |
| 12 | Dig Out 5 (Warning Temperature control unit) | 25 | Iso GND In (eDAQ or Machine) |
| 13 | Dig Out 6 (Good part) | | |

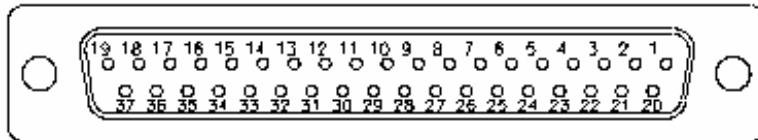

Connecting Cable
Type 1239A5 (yellow)

| Pin | Function | Pin | Function |
|-----|------------------------|-----|------------|
| 1 | - In Ch1 (Supply GND) | 20 | + In Ch1 |
| 2 | - In Ch2 (Supply GND) | 21 | + In Ch2 |
| 3 | - In Ch3 (Supply GND) | 22 | + In Ch3 |
| 4 | - In Ch4 (Supply GND) | 23 | + In Ch4 |
| 5 | - In Ch5 (Supply GND) | 24 | + In Ch5 |
| 6 | - In Ch6 (Supply GND) | 25 | + In Ch6 |
| 7 | - In Ch7 (Supply GND) | 26 | + In Ch7 |
| 8 | - In Ch8 (Supply GND) | 27 | + In Ch8 |
| 9 | - In Ch9 (Supply GND) | 28 | + In Ch9 |
| 10 | - In Ch10 (Supply GND) | 29 | + In Ch10 |
| 11 | - In Ch11 (Supply GND) | 30 | + In Ch11 |
| 12 | - In Ch12 (Supply GND) | 31 | + In Ch12 |
| 13 | - In Ch13 (Supply GND) | 32 | + In Ch13 |
| 14 | - In Ch14 (Supply GND) | 33 | + In Ch14 |
| 15 | - In Ch15 (Supply GND) | 34 | + In Ch15 |
| 16 | - In Ch16 (Supply GND) | 35 | + In Ch16 |
| 17 | Supply GND | 36 | Supply GND |
| 18 | Supply GND | 37 | Supply GND |
| 19 | Supply GND | | |

Subject to technical amendments

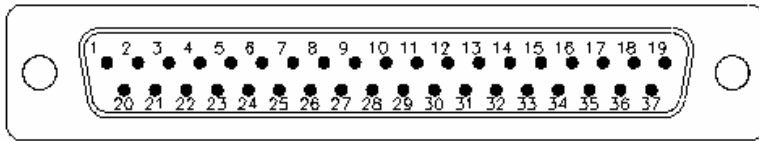

Connecting Cable
Type 1236A5 (green)

| Pin | Function | Pin | Function |
|-----|--------------------------------------|-----|---|
| 1 | Alarm2 CH 1 | 20 | Dig In option CH2 (Rotary table) |
| 2 | Alarm2 CH 2 | 21 | Dig In option CH3 (Start-up circuit) |
| 3 | Alarm2 CH 3 | 22 | Dig In option CH4 |
| 4 | Alarm2 CH 4 | 23 | Dig In option CH5 |
| 5 | Alarm2 CH 5 | 24 | Dig In option CH6 |
| 6 | Alarm2 CH 6 | 25 | Dig In option CH7 |
| 7 | Alarm2 CH 7 | 26 | Dig In option CH8 |
| 8 | Alarm2 CH 8 | 27 | Dig In option CH9 |
| 9 | Alarm2 CH 9 | 28 | Dig In option CH10 |
| 10 | Alarm2 CH 10 | 29 | Dig In option CH11 |
| 11 | Alarm2 CH 11 | 30 | Dig In option CH12 |
| 12 | Alarm2 CH 12 | 31 | Dig In option CH13 |
| 13 | Alarm2 CH 13 | 32 | Dig In option CH14 |
| 14 | Alarm2 CH 14 | 33 | Dig In option CH15 |
| 15 | Alarm2 CH 15 | 34 | Dig In option CH16 |
| 16 | Alarm2 CH 16 | 35 | Iso Supply in (eDAQ or machine) V+ |
| 17 | Dig Out 1 (Machine STOP) | 36 | Common logic in (Dig In option CH 1/16) |
| 18 | Dig Out 2 (Balance/Control On / Off) | 37 | Iso GND in (eDAQ or machine) |
| 19 | DigIn option CH1 (Rotary table) | | |

Clamp interface machine side PDDI type 8903E2

| | | | | | | | | | | | | | | | | | | | |
|---|---|---|---|---|---|---|---|---|----|----|----|----|----|----|----|----|----|----|----|
| 1 | 2 | 3 | 4 | 5 | 6 | 7 | 8 | 9 | 10 | 11 | 12 | 13 | 14 | 15 | 16 | 17 | 18 | 19 | 20 |
| | | | | | | | | | | | | | | | | | | | |

| | | | | | | | | | | | | | | | | | | | |
|----|----|----|----|----|----|----|----|----|----|----|----|----|----|----|----|----|----|----|----|
| | | | | | | | | | | | | | | | | | | | |
| 21 | 22 | 23 | 24 | 25 | 26 | 27 | 28 | 29 | 30 | 31 | 32 | 33 | 34 | 35 | 36 | 37 | 38 | 39 | 40 |

| | | | | | | | | | | | | | | | | | | | |
|----|----|----|----|----|----|----|----|----|----|----|----|----|----|----|----|----|----|----|----|
| 41 | 42 | 43 | 44 | 45 | 46 | 47 | 48 | 49 | 50 | 51 | 52 | 53 | 54 | 55 | 56 | 57 | 58 | 59 | 60 |
| | | | | | | | | | | | | | | | | | | | |

| | | | | | | | | | | | | | | | | | | | |
|----|----|----|----|----|----|----|----|----|----|----|----|----|----|----|----|----|----|----|----|
| | | | | | | | | | | | | | | | | | | | |
| 61 | 62 | 63 | 64 | 65 | 66 | 67 | 68 | 69 | 70 | 71 | 72 | 73 | 74 | 75 | 76 | 77 | 78 | 79 | 80 |

Subject to technical amendments



| Signal | Clamp # | Interface | Signal | Clamp # | Interface |
|---|---------|---------------------------------|--|---------|-----------------------------|
| Dig_Out Alarm2 CH1 DSUB 37 Green | 1 | Alarm Cavity 1 +24V to Machine | Analog ±10V + In Ch2 | | Voltage CH1 ±10V Input |
| Dig_Out Alarm2 CH2 | 2 | Alarm Cavity 2 +24V to Machine | Analog ±10V + In Ch3 | | Voltage CH2 ±10V Input |
| Dig_Out Alarm2 CH3 | 3 | Alarm Cavity 3 +24V to Machine | Analog ±10V + In Ch4 | | Voltage CH3 ±10V Input |
| Dig_Out Alarm2 CH4 | 4 | Alarm Cavity 4 +24V to Machine | Analog ±10V + In Ch5 | | Voltage CH4 ±10V Input |
| Dig_Out Alarm2 CH5 | 5 | Alarm Cavity 5 +24V to Machine | Analog ±10V + In Ch6 | | Voltage CH5 ±10V Input |
| Dig_Out Alarm2 CH6 | 6 | Alarm Cavity 6 +24V to Machine | Analog ±10V + In Ch7 | | Voltage CH6 ±10V Input |
| Dig_Out Alarm2 CH7 | 7 | Alarm Cavity 7 +24V to Machine | Analog ±10V + In Ch8 | | Voltage CH7 ±10V Input |
| Dig_Out Alarm2 CH8 | 8 | Alarm Cavity 8 +24V to Machine | Analog ±10V + In Ch9 | | Voltage CH8 ±10V Input |
| Dig_Out Alarm2 CH9 | 9 | Alarm Cavity 9 +24V to Machine | Analog ±10V + In Ch10 | | Voltage CH9 ±10V Input |
| Dig_Out Alarm2 CH10 | 10 | Alarm Cavity 10 +24V to Machine | Analog ±10V + In Ch11 | | Voltage CH10 ±10V Input |
| Dig_Out Alarm2 CH11 | 11 | Alarm Cavity 11 +24V to Machine | Analog ±10V + In Ch12 | | Voltage CH11 ±10V Input |
| Dig_Out Alarm2 CH12 | 12 | Alarm Cavity 12 +24V to Machine | Analog ±10V + In Ch13 | | Voltage CH12 ±10V Input |
| Dig_Out Alarm2 CH13 | 13 | Alarm Cavity 13 +24V to Machine | Analog ±10V + In Ch14 | | Voltage CH13 ±10V Input |
| Dig_Out Alarm2 CH14 | 14 | Alarm Cavity 14 +24V to Machine | Analog ±10V + In Ch15 | | Voltage CH14 ±10V Input |
| Dig_Out Alarm2 CH15 | 15 | Alarm Cavity 15 +24V to Machine | Analog ±10V + In Ch16 | | Voltage CH15 ±10V Input |
| Dig_Out Alarm2 CH16 | 16 | Alarm Cavity 16 +24V to Machine | Dig Out 3 (Warning Hot runner) | | +24 V to Machine |
| Dig_Out DIG_OUT1 (Machine STOP) | 17 | +24V to Machine | Dig Out 4 (Warning max. Balancing time) | | +24 V to Machine |
| Dig_Out DIG_OUT2 (Balance/Control On / Off) | 18 | +24V to Machine | Dig Out 5 (Warning Temperature control unit) | | +24 V to Machine |
| Dig_In DigIn Option CH1 (Rotary table) | 19 | +24V from Machine | Dig Out 6 (Good part) | | +24 V to Machine |
| Dig_In DigIn Option CH2 (Rotary table) | 20 | +24V from Machine | Dig Out 7 (Bad part) | | +24 V to Machine |
| Dig_In DigIn Option CH3 (Start-up circuit) | 21 | +24V from Machine | Analog ±10V Out Ch1 | | Out CH1 ±10V to Machine |
| Dig_In DigIn Option CH4 | 22 | +24V from Machine | Analog ±10V Out Ch2 | | Out CH2 ±10V to Machine |
| Dig_In DigIn Option CH5 | 23 | +24V from Machine | Analog ±10V Out Ch3 | | Out CH3 ±10V to Machine |
| Dig_In DigIn Option CH6 | 24 | +24V from Machine | Analog ±10V Out Ch4 | | Out CH4 ±10V to Machine |
| Dig_In DigIn Option CH7 | 25 | +24V from Machine | Analog ±10V Out Ch5 | | Out CH5 ±10V to Machine |
| Dig_In Dig In Option CH8 | 26 | +24V from Machine | Analog ±10V Out Ch6 | | Out CH6 ±10V to Machine |
| Dig_In DigIn Option CH9 | 27 | +24V from Machine | Analog ±10V Out Ch7 | | Out CH7 ±10V to Machine |
| Dig_In DigIn Option CH10 | 28 | +24V from Machine | Analog ±10V Out Ch8 | | Out CH8 ±10V to Machine |
| Dig_In DigIn Option CH11 | 29 | +24V from Machine | Analog ±10V Out Ch9 | | Out CH9 ±10V to Machine |
| Dig_In DigIn Option CH12 | 30 | +24V from Machine | Analog ±10V Out Ch10 | | Out CH10 ±10V to Machine |
| Dig_In DigIn Option CH13 | 31 | +24V from Machine | Analog ±10V Out Ch11 | | Out CH11 ±10V to Machine |
| Dig_In DigIn Option CH14 | 32 | +24V from Machine | Analog ±10V Out Ch12 | | Out CH12 ±10V to Machine |
| Dig_In DigIn Option CH15 | 33 | +24V from Machine | Analog ±10V Out Ch13 | | Out CH13 ±10V to Machine |
| Dig_In DigIn Option CH16 | 34 | +24V from Machine | Analog ±10V Out Ch14 | | Out CH14 ±10V to Machine |
| Iso Supply In (eDAQ or Machine, V+) | 35 | +24V Machine | Analog ±10V Out Ch15 | | Out CH15 ±10V to Machine |
| Common logic In (DigIn Option CH 1...16) | 36 | GND from Machine | Analog ±10V Out Ch16 | | Out CH16 ±10V to Machine |
| Iso GND In (eDAQ oder Machine) | 37 | GND from Machine | Supply GND | | GND (Analog out) to Machine |
| Analog ±10V + In Ch1 - Ch16 DSUB 37 Yellow | | GND from analog signals | Signal GND | | GND (Analog out) to Machine |
| Analog ±10V + In Ch1- Ch16 | | GND from analog signals | Iso Supply In (eDAQ or Machine, V+) | | +24V from Machine |
| Analog ±10V + In Ch1 | | Voltage CH1 | Iso GND In (eDAQ or Machine) | | GND from Machine |

Subject to technical amendments

PDDI type 8903B3

The PDDI Type 8903B3 is used for interfacing following signals:

| Signal | Description | Interface |
|--|--|--|
| SL CH1...16 Alarm CH1...16 DigIn_1...DigIn_5 Common logic in SLP CH1...16 Auto switchover2 | Control signals (switchover by level) Individual alarm signals digital input signals (status signals) Reference point for DigIn signals Automatic switchover signals (sequential) Additional common automatic switchover signal | +24 V to machine +24 V to machine +24 V to eDAQ™ GND from machine +24 V to machine +24 V to machine |
| Iso supply out eDAQ V+ Iso GND out eDAQ Iso supply in (eDAQ or machine) V+ Iso GND in (eDAQ or machine) | Supply of the output stages by the eDAQ Supply GND of the output stages (eDAQ™) Supply of the output stages by the machine Supply GND of the output stages (machine) | +24 V from eDAQ™ GND from eDAQ™ +24 V from machine GND from machine |

Dimensions PDDI type 8903B3

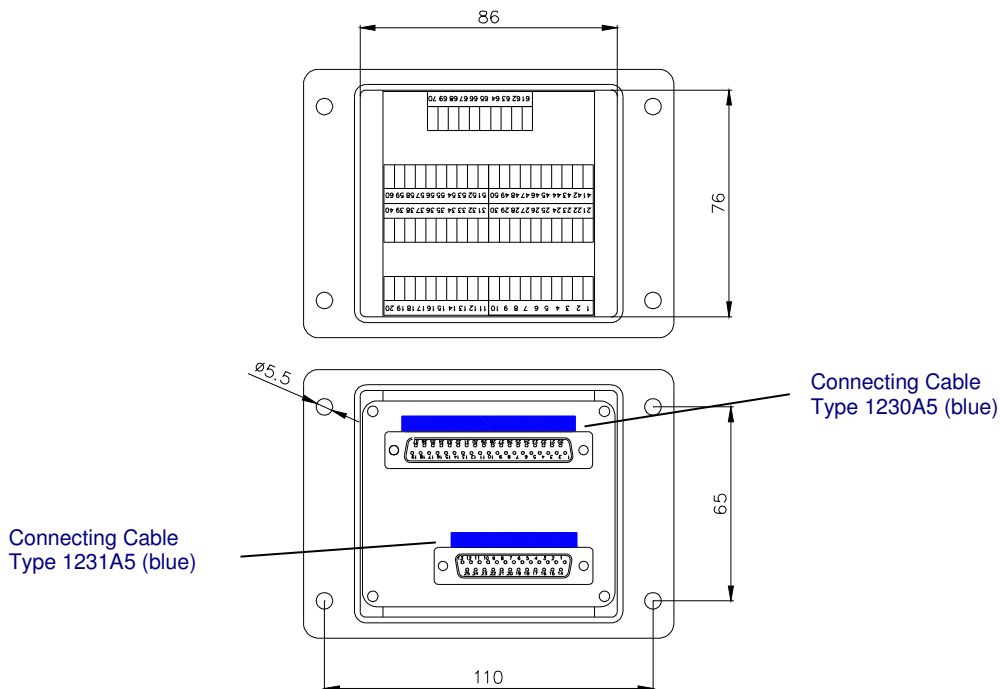

Subject to technical amendments

Pin allocation PDDI type 8903B3

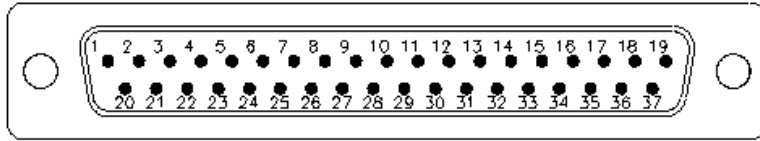

Connecting Cable
Type 1230A5 (blue)

| Pin | Function | Pin | Function |
|-----|------------|-----|------------------------------------|
| 1 | SL CH 1 | 20 | Alarm CH 4 |
| 2 | SL CH 2 | 21 | Alarm CH 5 |
| 3 | SL CH 3 | 22 | Alarm CH 6 |
| 4 | SL CH 4 | 23 | Alarm CH 7 |
| 5 | SL CH 5 | 24 | Alarm CH 8 |
| 6 | SL CH 6 | 25 | Alarm CH 9 |
| 7 | SL CH 7 | 26 | Alarm CH 10 |
| 8 | SL CH 8 | 27 | Alarm CH 11 |
| 9 | SL CH 9 | 28 | Alarm CH 12 |
| 10 | SL CH 10 | 29 | Alarm CH 13 |
| 11 | SL CH 11 | 30 | Alarm CH 14 |
| 12 | SL CH 12 | 31 | Alarm CH 15 |
| 13 | SL CH 13 | 32 | Alarm CH 16 |
| 14 | SL CH 14 | 33 | DigIn_4 |
| 15 | SL CH 15 | 34 | DigIn_5 |
| 16 | SL CH 16 | 35 | Iso supply in (eDAQ or machine) V+ |
| 17 | Alarm CH 1 | 36 | Common logic in (DigIn_4/5) |
| 18 | Alarm CH 2 | 37 | Iso GND in (eDAQ or machine) |
| 19 | Alarm CH 3 | | |

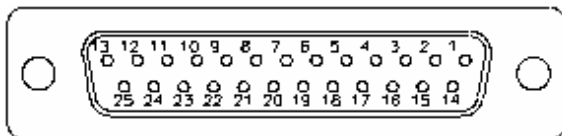

Connecting Cable
Type 1231A5 (blue)

| Pin | Function | Pin | Function |
|-----|-----------|-----|--|
| 1 | SLP Ch 1 | 14 | SLP Ch 14 |
| 2 | SLP Ch 2 | 15 | SLP Ch 15 |
| 3 | SLP Ch 3 | 16 | SLP Ch 16 |
| 4 | SLP Ch 4 | 17 | Auto_switchover ² , (ComSLP ² , SLP collective ² ,) |
| 5 | SLP Ch 5 | 18 | DigIn_1 |
| 6 | SLP Ch 6 | 19 | DigIn_2 |
| 7 | SLP Ch 7 | 20 | DigIn_3 |
| 8 | SLP Ch 8 | 21 | Iso Supply in (eDAQ or machine) V+ |
| 9 | SLP Ch 9 | 22 | Iso GND in (eDAQ or machine) |
| 10 | SLP Ch 10 | 23 | Common logic in (DigIn_1/3) |
| 11 | SLP Ch 11 | 24 | Iso supply out eDAQ V+ |
| 12 | SLP Ch 12 | 25 | Iso GND out eDAQ |
| 13 | SLP Ch 13 | | |

Subject to technical amendments



Clamp interface machine side PDDI type 8903A3

| | | | | | | | | | | | | | | | | | | | |
|---|---|---|---|---|---|---|---|---|----|----|----|----|----|----|----|----|----|----|----|
| 1 | 2 | 3 | 4 | 5 | 6 | 7 | 8 | 9 | 10 | 11 | 12 | 13 | 14 | 15 | 16 | 17 | 18 | 19 | 20 |
| | | | | | | | | | | | | | | | | | | | |

| | | | | | | | | | | | | | | | | | | | |
|----|----|----|----|----|----|----|----|----|----|----|----|----|----|----|----|----|----|----|----|
| | | | | | | | | | | | | | | | | | | | |
| 21 | 22 | 23 | 24 | 25 | 26 | 27 | 28 | 29 | 30 | 31 | 32 | 33 | 34 | 35 | 36 | 37 | 38 | 39 | 40 |
| 41 | 42 | 43 | 44 | 45 | 46 | 47 | 48 | 49 | 50 | 51 | 52 | 53 | 54 | 55 | 56 | 57 | 58 | 59 | 60 |
| | | | | | | | | | | | | | | | | | | | |

| | | | | | | | | | |
|----|----|----|----|----|----|----|----|----|----|
| | | | | | | | | | |
| 61 | 62 | 63 | 64 | 65 | 66 | 67 | 68 | 69 | 70 |

| Signal | Clamp # | Interface | Signal | Clamp # | Interface |
|---------------------|---------|-----------------------------|-------------------------------------|---------|-------------------------------------|
| Dig Out SL CH 1 | 1 | +24V to Machine | Iso Supply In (eDAQ or Machine, V+) | 36 | +24V from Machine |
| Dig Out SL CH 2 | 2 | +24V to Machine | Common logic In (DigIn_ 4...5) | 37 | GND from Machine |
| Dig Out SL CH 3 | 3 | +24V to Machine | Iso GND In (eDAQ or Machine) | 38 | GND from Machine |
| Dig Out SL CH 4 | 4 | +24V to Machine | NC | 39 | NC |
| Dig Out SL CH 5 | 5 | +24V to Machine | NC | 40 | NC |
| Dig Out SL CH 6 | 6 | +24V to Machine | Dig Out SLP Ch 1 D-Sub 25 | 41 | Sequential CH1 +24V to Machine |
| Dig Out SL CH 7 | 7 | +24V to Machine | Dig Out SLP Ch 2 | 42 | Sequential CH2 +24V to Machine |
| Dig Out SL CH 8 | 8 | +24V to Machine | Dig Out SLP Ch 3 | 43 | Sequential CH3 +24V to Machine |
| Dig Out SL CH 9 | 9 | +24V to Machine | Dig Out SLP Ch 4 | 44 | Sequential CH4 +24V to Machine |
| Dig Out SL CH 10 | 10 | +24V to Machine | Dig Out SLP Ch 5 | 45 | Sequential CH5 +24V to Machine |
| Dig Out SL CH 11 | 11 | +24V to Machine | Dig Out SLP Ch 6 | 46 | Sequential CH6 +24V to Machine |
| Dig Out SL CH 12 | 12 | +24V to Machine | Dig Out SLP Ch 7 | 47 | Sequential CH7 +24V to Machine |
| Dig Out SL CH 13 | 13 | +24V to Machine | Dig Out SLP Ch 8 | 48 | Sequential CH8 +24V to Machine |
| Dig Out SL CH 14 | 14 | +24V to Machine | Dig Out SLP Ch 9 | 49 | Sequential CH9 +24V to Machine |
| Dig Out SL CH 15 | 15 | +24V to Machine | Dig Out SLP Ch 10 | 50 | Sequential CH10 +24V to Machine |
| Dig Out SL CH 16 | 16 | +24V to Machine | Dig Out SLP Ch 11 | 51 | Sequential CH11 +24V to Machine |
| Dig Out Alarm CH 1 | 17 | +24V to Machine | Dig Out SLP Ch 12 | 52 | Sequential CH12 +24V to Machine |
| Dig Out Alarm CH 2 | 18 | +24V to Machine | Dig Out SLP Ch 13 | 53 | Sequential CH13 +24V to Machine |
| Dig Out Alarm CH 3 | 19 | +24V to Machine | Dig Out SLP Ch 14 | 54 | Sequential CH14 +24V to Machine |
| NC | 20 | NC | Dig Out SLP Ch 15 | 55 | Sequential CH15 +24V to Machine |
| Dig Out Alarm CH 4 | 21 | +24V to Machine | Dig Out SLP Ch 16 | 56 | Sequential CH16 +24V to Machine |
| Dig Out Alarm CH 5 | 22 | +24V to Machine | NC | 57 | NC |
| Dig Out Alarm CH 6 | 23 | +24V to Machine | NC | 58 | NC |
| Dig Out Alarm CH 7 | 24 | +24V to Machine | Iso Supply In (eDAQ or Machine, V+) | 59 | +24V Machine |
| Dig Out Alarm CH 8 | 25 | +24V to Machine | Iso GND In (eDAQ or Machine) | 60 | GND from Machine |
| Dig Out Alarm CH 9 | 26 | +24V to Machine | Dig Out Auto Switchover 2 | 61 | +24V to Machine |
| Dig Out Alarm CH 10 | 27 | +24V to Machine | DigIn_1 | 62 | Start Injection +24V to eDAQ |
| Dig Out Alarm CH 11 | 28 | +24V to Machine | DigIn_2 | 63 | Switchover Signal +24V to eDAQ |
| Dig Out Alarm CH 12 | 29 | +24V to Machine | DigIn_3 | 64 | Start Holding Pressure +24V to eDAQ |
| Dig Out Alarm CH 13 | 30 | +24V to Machine | Iso Supply In (eDAQ or Machine, V+) | 65 | +24V from Machine |
| Dig Out Alarm CH 14 | 31 | +24V to Machine | Iso Supply Out (eDAQ, V+) | 66 | +24V from eDAQ |
| Dig Out Alarm CH 15 | 32 | +24V to Machine | Common logic In (DigIn_1...3) | 67 | GND from Machine |
| Dig Out Alarm CH 16 | 33 | +24V to Machine | Iso GND In (eDAQ or Machine) | 68 | GND from Machine |
| DigIn_4 | 34 | Start Cooling +24V zum eDAQ | Iso GND Out (eDAQ) | 69 | GND from eDAQ |
| DigIn_5 | 35 | +24V zum eDAQ | NC | 70 | |

Subject to technical amendments

Interfacing of the digital output signals (example: switchover to holding pressure)

Digital Output Signals: Supply of the output stages by the machine

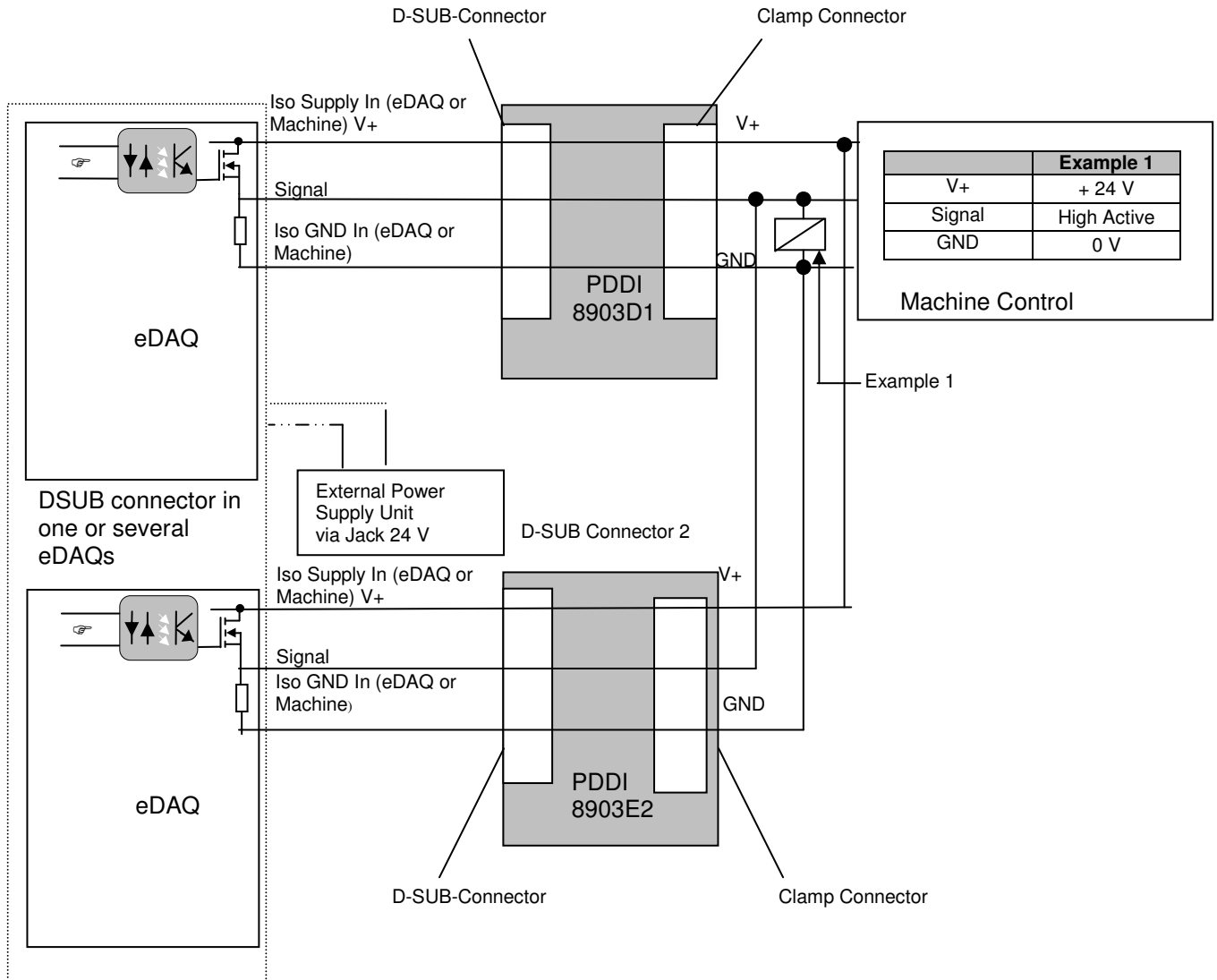

Subject to technical amendments

Interfacing of the digital input signals (example: start holding pressure)

Digital input signals

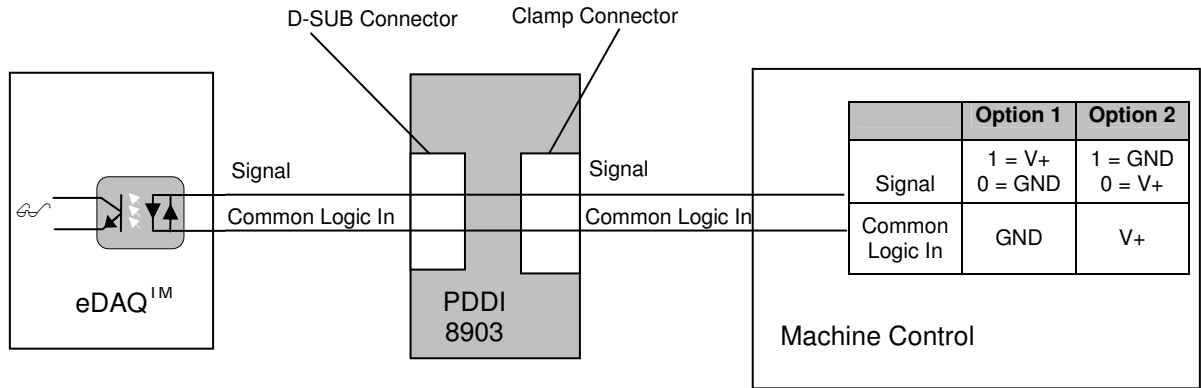

PDDI 8903D1

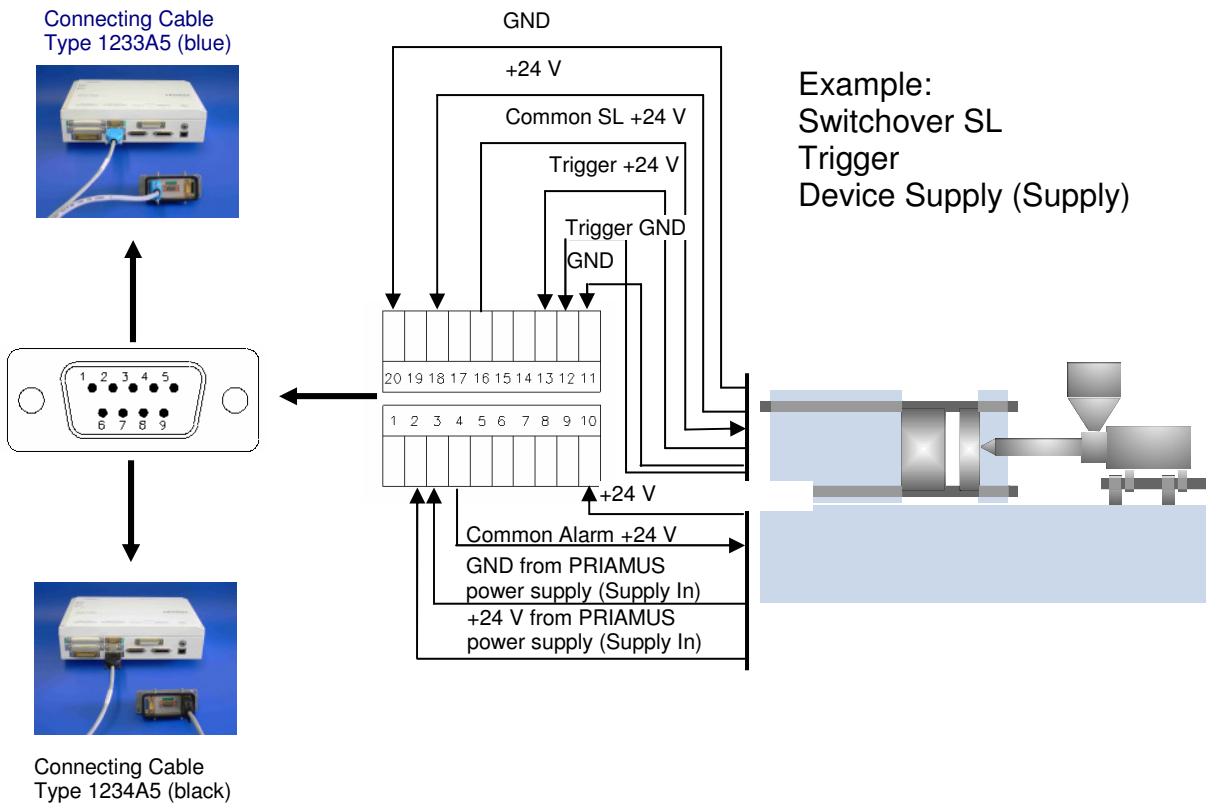

Subject to technical amendments

PDDI 8903B3

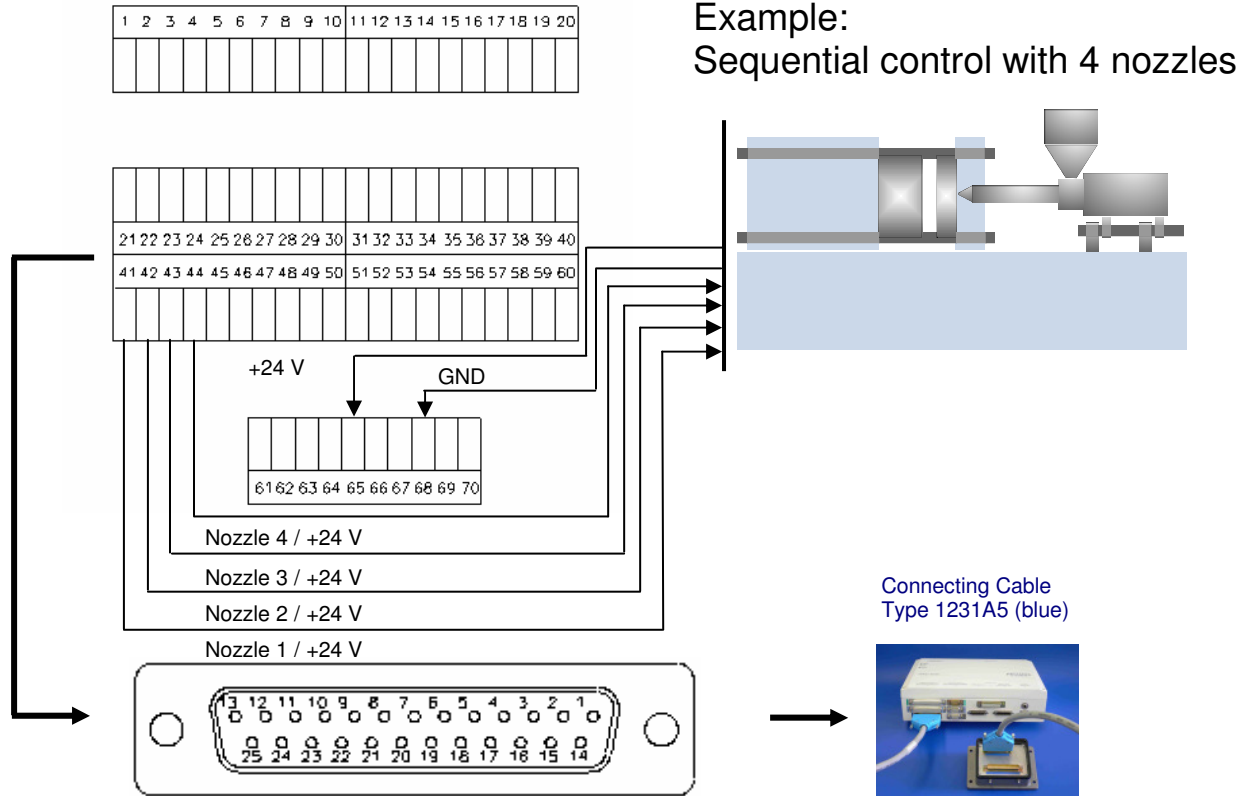

PDDI 8903E2

Example: Alarm signals PRIAMUS Fill

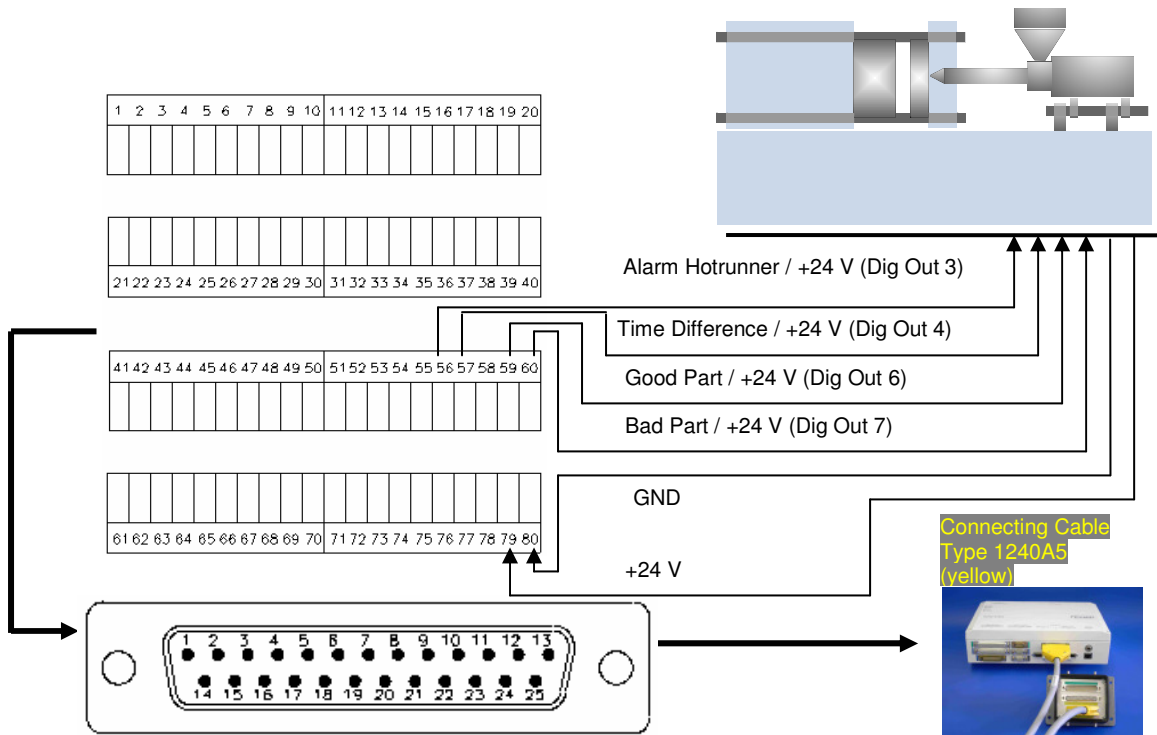

Subject to technical amendments