

PRIAMUS SYSTEM TECHNOLOGIES, LLC
3061 Nationwide Parkway
Brunswick, OH 44212 / USA

Phone +1 (877) 774 2687
salesus@priamus.com
www.priamus.com

PRIAMUS SYSTEM TECHNOLOGIES AG
Bahnhofstrasse 36
CH-8201 Schaffhausen / Switzerland

Phone +41 (0)52 632 2626
Fax +41 (0)52 632 2627
www.priamus.com



Pass Controller Type 8104

Process control, process reliability and production efficiency
Compact, simple and transparent



THE SWISS WAY TO IMPROVE THE QUALITY OF YOUR PLASTIC PRODUCTS

The Pass Controller

PRIAMUS breaks new ground for injection molding process control with the Pass Controller. Independent on how molded parts are manufactured, if the cavity pressure and the cavity temperature of the molded part and the viscosity of the melt are within a defined monitoring window, a good part is produced. If the values are outside this window, the bad part is automatically identified and if necessary, rejected.

The Pass Controller shows this very clearly with bright light emitting diodes (LED's). Green indicates good parts; red indicates bad parts.



The Pass Controller was especially designed for easy handling and operation in a manufacturing environment. It is a compact monitoring device conforming to industrial standards. The settings can be entered quickly using the integrated touch screen display.

Basic Technical Data

- Up to 8 channels cavity pressure, cavity temperature or machine signals (voltage)
- Connection of the measuring signals with waterproof multi pin connectors
- Waterproof Ethernet interface for data transfer
- Digital outputs
 - For reject control (alarm)
 - For switchover to holding pressure (fixed level of cavity pressure)
 - For automatic switchover to holding pressure (cavity temperature)
- 8 analog outputs (measuring signals)
- Automatic monitoring of
 - Minimum values
 - Maximum values
 - Integral values
 - Mold surface temperature
 - Switchover times
 - Viscosity
 - Cycle time

Very easy handling

The necessary inputs have been specifically reduced to a minimum. The few remaining settings of the Pass Controller can be entered easily with the integrated color touch screen display.

Accessories like computer mouse or keyboard are not necessary.

- Compact and yet powerful
- Intelligent and yet easy to operate



Easy magnetic mounting



The Pass Controller can be mounted to the machine – as usual.

But there is more behind it!

Integrated magnetic feature allows for easy mounting and flexibility for the device location.

- Mobile and immediately visible for the production staff

SD memory card – easy data storage

The Pass Controller has a slot for commercial SD memory cards like those used for cameras.

SD memory cards store for example multiple mold configurations. This allows for great flexibility in the data handling.



Waterproof concept

The multi-pin connector interfaces for the device are completely waterproof.

Even the Ethernet connection for data transfer / networking is waterproof.

Whatever happens, the device is safe!



Clever color coded concept



In order to connect the different connectors simply, PRIAMUS has implemented a color coding for all cables.

This foolproof concept makes interfacing very easy.

No mix-up of cables!

Why not travelling?

The Pass Controller is not only intended for stationary use. Many molds are often not run in production at the same place where they have been set up. And many molders and companies have different production sites. The Pass Controller assures that the production is done in the same way as the mold set up. No matter in which country, no matter on which continent. The parts are good when the green LED shines.

Another convenient feature: An integrated cycle counter reports if the mold needs maintenance.



How does the Pass Controller work?

The Pass Controller monitors and controls the injection molding production. The optimal settings are identified during the mold set up process. Then the process is effectively validated and ready for production.

From now on the molded parts must be produced under these validated conditions. However, it is the optimized condition of the parts which must be reproduced – not the settings of the machine. That means it makes no sense to transfer the machine settings.

“Characteristic numbers” of the molded part associated, for example, with maximum cavity pressure or the maximum cavity temperature are being saved as definite identifying feature.

If the mold is set up on a different machine, the settings of the machine need to be changed until the “characteristic numbers” are within a certain tolerance.

If this is the case, a green LED shines and approves the start for guaranteed optimized molded parts.

Bad part



Good part

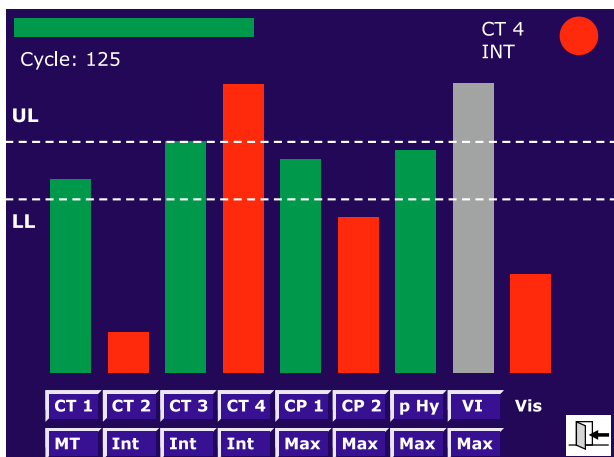
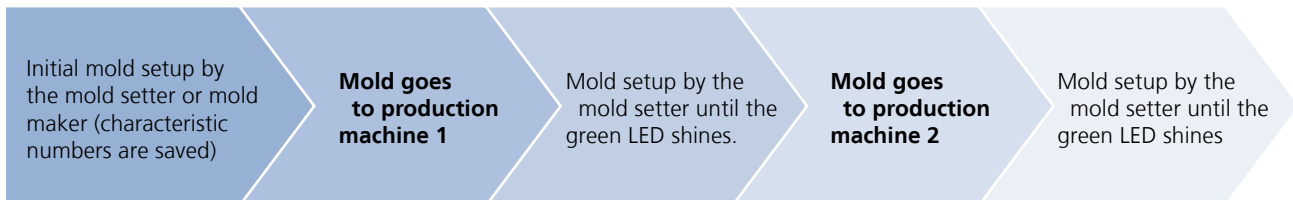

A free configurable bar chart shows at a glance if the characteristic numbers of the molded part are within the selected or the automatic determined tolerances.

Online, automatic viscosity monitoring

The viscosity of the melt is an important factor for material evaluation and process consistency. If the material properties from batch to batch and the temperature relationships change with same machine settings, identical parts will not be produced.

Placement of one cavity pressure sensor near the gate and one cavity temperature sensor towards the end of flow al-

low the Pass Controller to monitor the viscosity directly in the mold. PRIAMUS has developed and patented this method to monitor the viscosity online. It shows at a glance if the flow characteristic has changed or not. If the deviation is too big, an alarm signal is available.

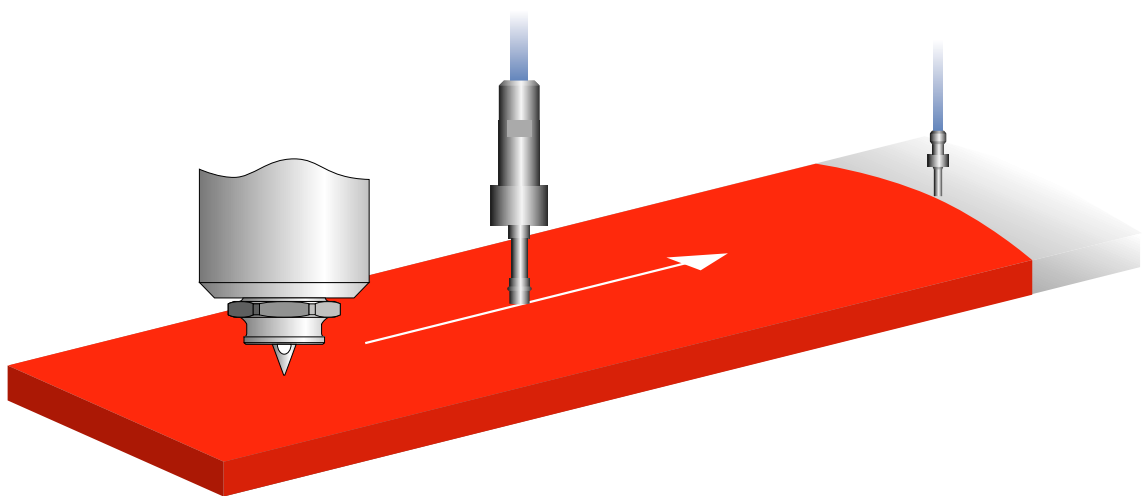

Sole precondition:
A cavity pressure sensor near the gate and a cavity temperature sensor preferably at the end of the flow path.

Automatic switchover to holding pressure

A very efficient and cost saving method to compensate or minimize the effects of viscosity variations, is the automatic switchover to holding pressure.

A cavity temperature sensor at the end of the flow path recognizes when the melt arrives there. If the viscosity changes, the cavity is filled faster or slower. The switchover occurs only when the mold is volumetrically full.

- No overmolding or flash
- No early switchover
- No fill study

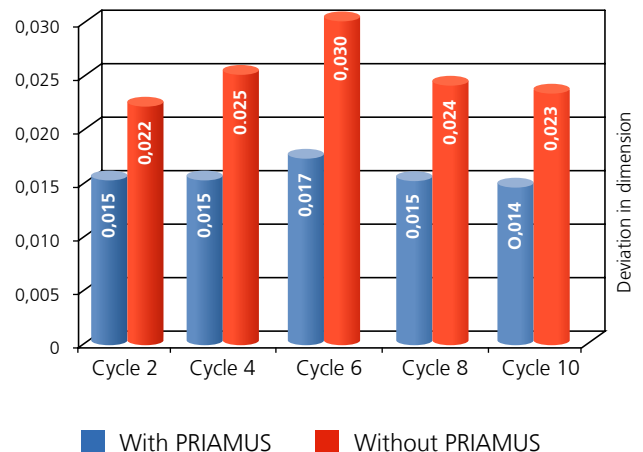

Automatic – simple – good

Who likes to talk about “PicoCoulomb per bar”?
 And this is not necessary!
 The Pass Controller automatically detects the sensitivity of the PRIASED™ cavity pressure sensors.

No need for manual input of the sensor sensitivity information.



Display of the measuring curve

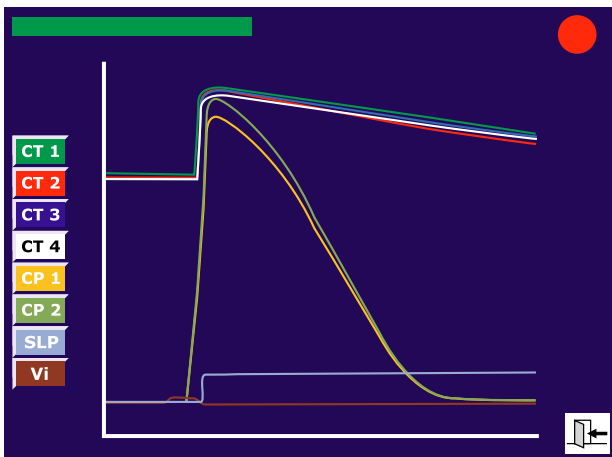

The classic display of the measuring curve serves particularly as support for process optimizing and process analysis.

For further processing (for example together with PRIAMUS Monitor or PRIAMUS Fill systems) the measuring data will be provided via Ethernet or analog.

Production efficiency

Information on the economic efficiency of the actual production becomes more and more important.

At a glance, the Pass Controller shows the number of good and bad parts produced. It displays also if the cycle time is within expectations. The number of good parts produced as well as detected downtime are used to calculate the production efficiency.

Production data at a glance.

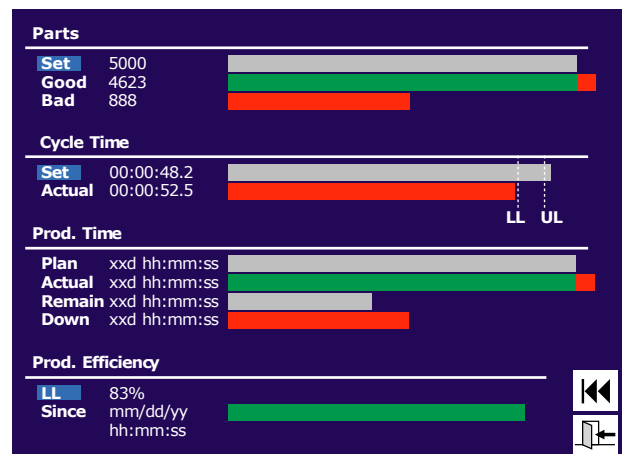

Compatible system networking

All PRIAMUS electronic devices and software systems are compatible via Ethernet interface. This means they can be easily combined. The Shop Floor Control system links these systems and devices together and documents the

production data on a server. This allows an immediate overview of production and summarizes the factors with greatest economic impact during operations.

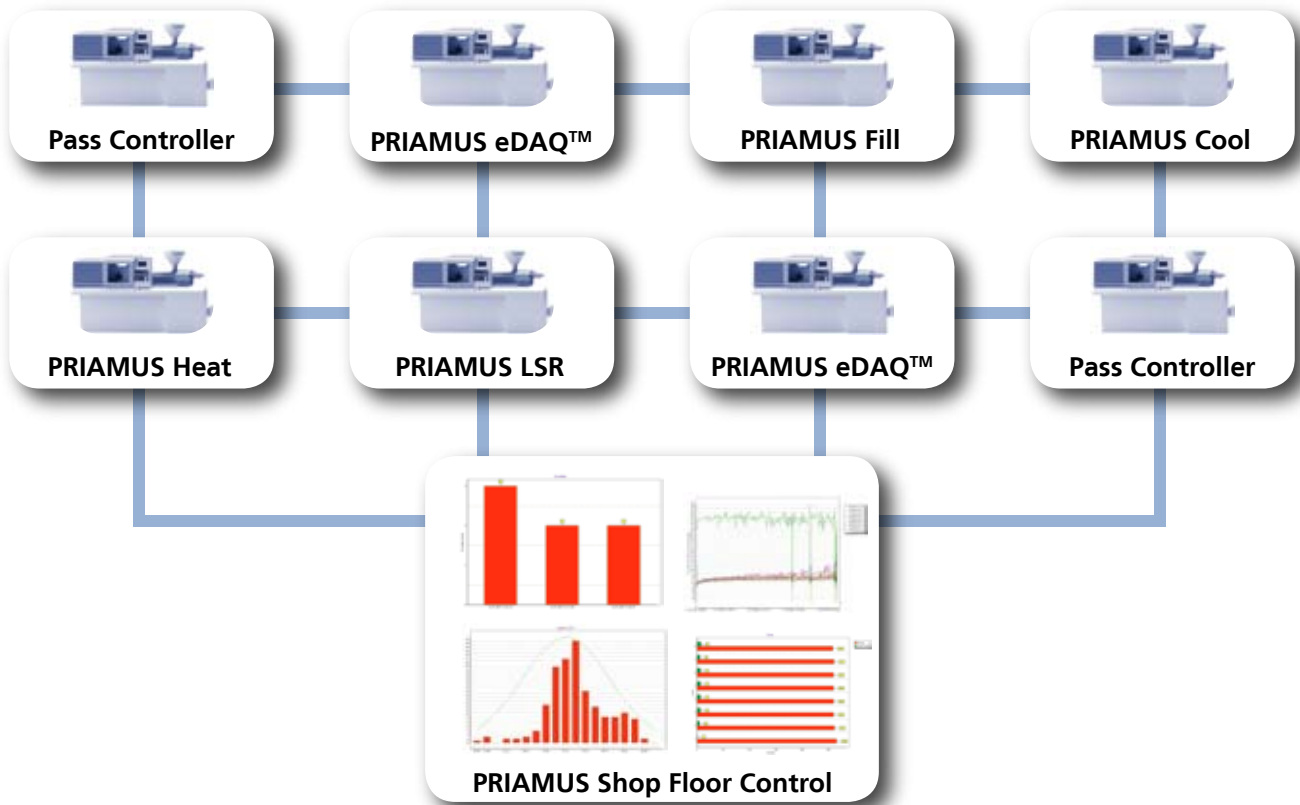

The Pass Controller – your advantages at a glance

- Very easy handling
- Quick installation
- Industrial, robust and waterproof
- Process monitoring directly at the part
- Viscosity monitoring
- Calculation of the production efficiency
- Inclusive SD memory card
- Magnetic mounting for mobile use
- Default monitoring limits
- Automatic switchover to holding pressure
- Cycle counter for mold maintenance
- Plant wide networking
- Can be combined with all PRIAMUS systems

